



# **Multiple Digital Message Unit**

Installation and Use Manual

Issue 2, January 2009

© 1999 Bogen Communications, Inc.  
All rights reserved. 54-2024-01B 0901  
Model: LUMDMU  
PEC Code: 5325-100  
COM Code: 408184000  
Select Code: 701-000-117

## Notice

Every effort was made to ensure that the information in this guide was complete and accurate at the time of printing. However, information is subject to change.

## FCC Statement (Part 15) - Radio Frequency Interference

The Multiple Digital Message Unit generates and uses radio frequency energy and if not installed and used in strict accordance with the manufacturer's instructions, may cause interference to radio and television reception. Testing is being conducted for compliance with the limits for a Class B device in accordance with the specifications in Part 15 of the FCC Rules and Canadian D.O.C. regulations. This testing is designed to provide reasonable protection against such interference. However, there is no guarantee that interference will not occur in a particular installation. If this equipment does cause interference to radio or television reception, which can be determined by turning the Multiple Digital Message Unit off and on, the user is encouraged to try to correct the interference by one or more of the following measures:

- Reorient the radio or TV receiving antenna.
- Relocate the Multiple Digital Message Unit with respect to the radio or TV receiver or vice-versa.
- Plug the Multiple Digital Message Unit into a different outlet so that it and the radio or TV receiver are on different branch circuits.

If necessary, the user should consult the dealer or an experienced radio/television technician for additional suggestions. The user may find the following booklet, "How To Identify and Resolve Radio-TV Interference Problems," helpful. This booklet was prepared by the Federal Communications Commission (FCC) and is available from the U.S. Government Printing Office, Washington, DC 20402. Stock order No. 004-000-00345-4.

## Federal Communications Commission (FCC) Statement (Part 68)

This equipment is component registered with the Federal Communications Commission (FCC) in accordance with Part 68 of its rules. In compliance with the rules, be advised of the following:

Registered equipment may not be used with Coin Telephone Lines. Equipment may be used with Party Lines in areas where state tariffs permit such connections and when equipment is adaptable for such service.

This equipment is registered as follows:  
Registration Number - F4PCAN-20988-AN-N  
Ringer Equivalence - 1.6B

If trouble is experienced, the equipment should be disconnected from the interface to determine if this equipment, or the telephone line is the trouble source. If the equipment is determined to be malfunctioning, it should not be reconnected until repairs are effected.

Repairs to this equipment, other than routine repairs, can be made only by the manufacturer or its authorized agents.

If the equipment causes harm to the telephone network, the local telephone company may temporarily discontinue your service and, if possible, notify you in advance. If advance notice is not practical, you will be notified as soon as possible. You will be given the opportunity to correct the problem and informed of your right to file a complaint with the FCC.

The local telephone company may make changes in its facilities, operations, or procedures that could affect the proper functioning of your equipment. If they do, you will be given adequate notice in writing to allow you an opportunity to maintain uninterrupted telephone service.

## Important Safety Information

Always follow these basic safety precautions when installing and using the system:

1. Read and understand all instructions.
2. Follow all warnings and instructions marked on the product.
3. DO NOT block or cover the ventilation slots and openings. They prevent the product from overheating. DO NOT place the product in a separate enclosure or cabinet, unless proper ventilation is provided.
4. Never spill liquid on the product or drop objects into the ventilation slots and openings. Doing so may result in serious damage to the components.
5. Repair or service must be performed by a factory authorized repair facility.
6. The product is provided with a CSA approved, 3-wire ground type plug. This is a safety feature. DO NOT defeat the safety purpose of the grounding type plug. DO NOT staple or otherwise attach the AC power supply cord to building surfaces.
7. DO NOT use the product near water or in a wet or damp place (such as a wet basement).
8. DO NOT use extension cords. The product must be installed within 6 feet of a grounded outlet receptacle.
9. DO NOT install telephone wiring during a lightning storm.
10. DO NOT install telephone jacks in a wet location unless the jack is specifically designed for wet locations.
11. Never touch uninsulated wires or terminals, unless the line has been disconnected at the paging or controller interface.
12. Use caution when installing or modifying paging or control lines.

## Support Information

Paging systems integrated with small phone systems such as Merlin Legend and Partner are supported by the National Service Assistance Center (NSAC). The main number for the NSAC is 800-628-2888. Paging systems integrated with large switches such as the DEFINITY G3 are supported by the Technical Service Center (TSC). The main number for the TSC is 800-242-2121.

## Domestic and International Approvals

CSA Certified LR55025; NRTL/C Certified; FCC Part 15 and Part 68.

# Table of Contents

---

Introduction	1
Before You Start	1
Installation Steps	2
Power Up System	6
Front Panel Operation	7
■ Controls and Indicators	7
■ Recording Messages	7
■ Listening to Recorded Messages	9
■ Playing Messages	10
■ Playing Messages in Sequence	11
■ Adding a Time Delay Between Message Plays	12
■ Clearing a Message Sequence	13
■ Checking Message Times	14
■ Reset Delay Times to Default	15
■ Audio and Memory Tests	15
Audio Test	15
Memory Test	16
Telephone Access Operation	17
■ Recording Messages	17
■ Listening to Recorded Messages	17
■ Playing Messages	18
■ Clearing a Message Sequence	18
Specifications	19

This page intentionally left blank

# Introduction

---

The Multiple Digital Messaging Unit (MDMU) is a micro processor based digital voice announcement system. It outputs prerecorded messages through a public address system. Up to 99 messages can be placed in the units digital memory for queued replay. Up to eight messages can be programmed to play in sequence with timed delays.

Depending on the amount of memory option configured in the MDMU, multiple messages can range from 32 seconds up to 8 minutes 44 seconds in length. Voice and audio messages can be stored into memory through dial-up telephone, microphone interface, or tape input. (The MDMU is programmed by dial-up telephone DTMF tones.)

This guide gives installation, recording, and programming steps. Since messages are digitally stored, and there are no moving parts, the MDMU should give years of uninterrupted service.

## Before You Start

---

Before installing your system, read and understand the safety instructions on page ii. Be sure you have all the necessary parts, tools, and test equipment, listed below.

**1**

Read important Safety Information on Page ii.

**2**

Check Shipping Container Contents.

- Multiple Digital Messaging Unit
- Mounting Hardware (screws and brackets)
- Cables, RJ-21 to wire lug end and power cord
- This Installation and Configuration guide

---

### 3

#### Have Required Tools

The following tools are required for the installation of the MDMU hardware and cabling.

- Phillips screwdriver (small and large)
- Standard blade screwdriver (small and large)
- Wire strippers (24 AWG - 12 AWG)
- Telephone test set
- Tone out circuit tester (optional, for troubleshooting)
- Volt-ohm Meter (optional, for troubleshooting)
- 4 wood screws, if mounted on wall

---

## Installation Steps

---

### 1

Mount the MDMU to either a wall, cabinet or a rack (near the paging equipment if possible).

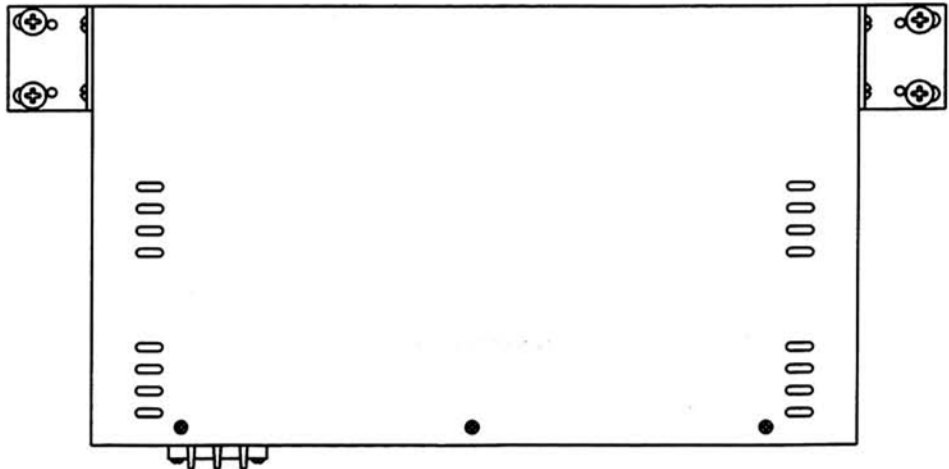

Figure 1. Wall Mounted Unit

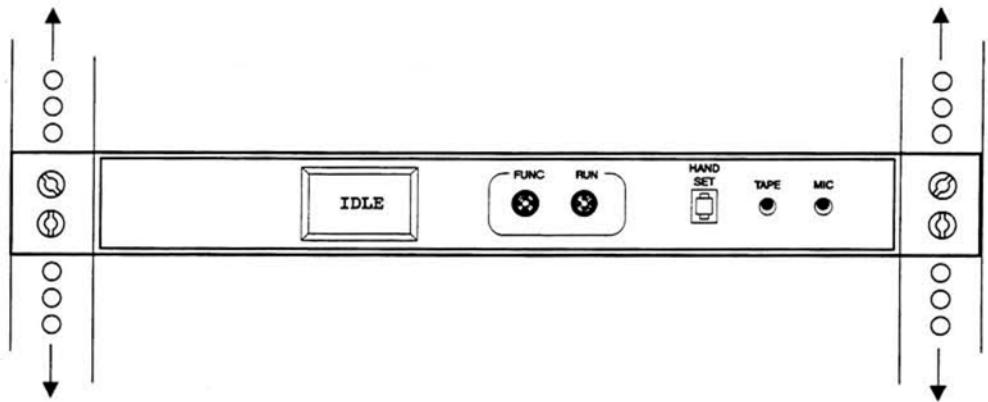

Figure 2. Rack Mounted MDMU

**2** Connect the MDMU to the Telephone System

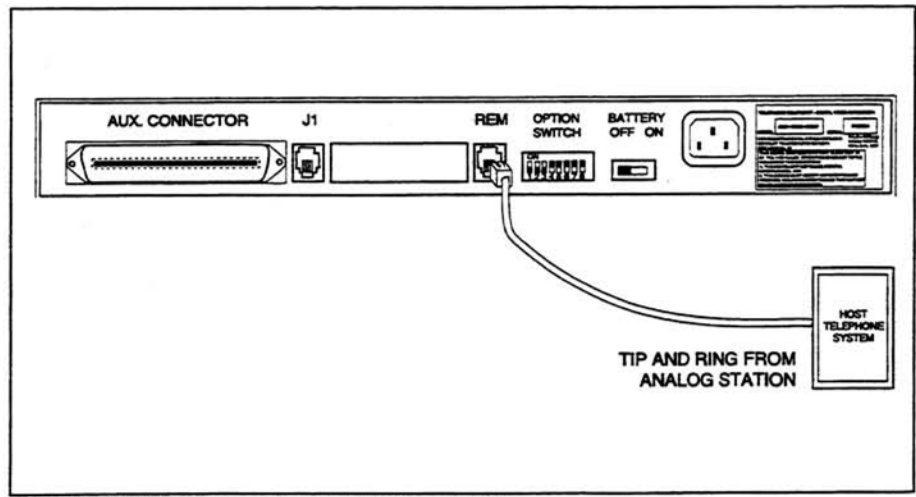

Figure 3 MDMU Connection to Telephone System

- 3 Plug the modular cord into connector J1 on MDMU and connect the wires on the other end to the Over Ride terminal.

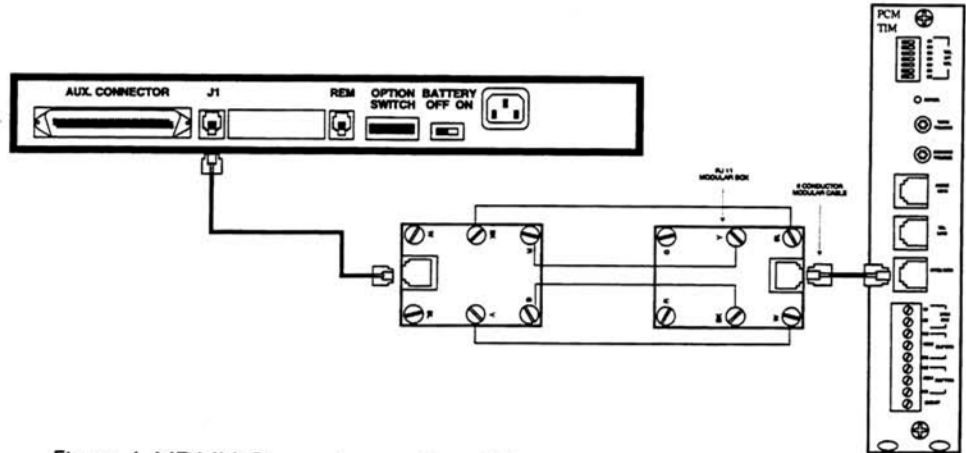

Figure 4. MDMU Connection to Over Ride

- 4 Connect the RJ-21 cable/connector to the MDMU Aux. Interface and to terminal block.

*NOTE: For specific pin-out information for this connector refer to Figure 9 at the end of this guide. Messages 1 through 6 correspond to message starts 1 through 6.*

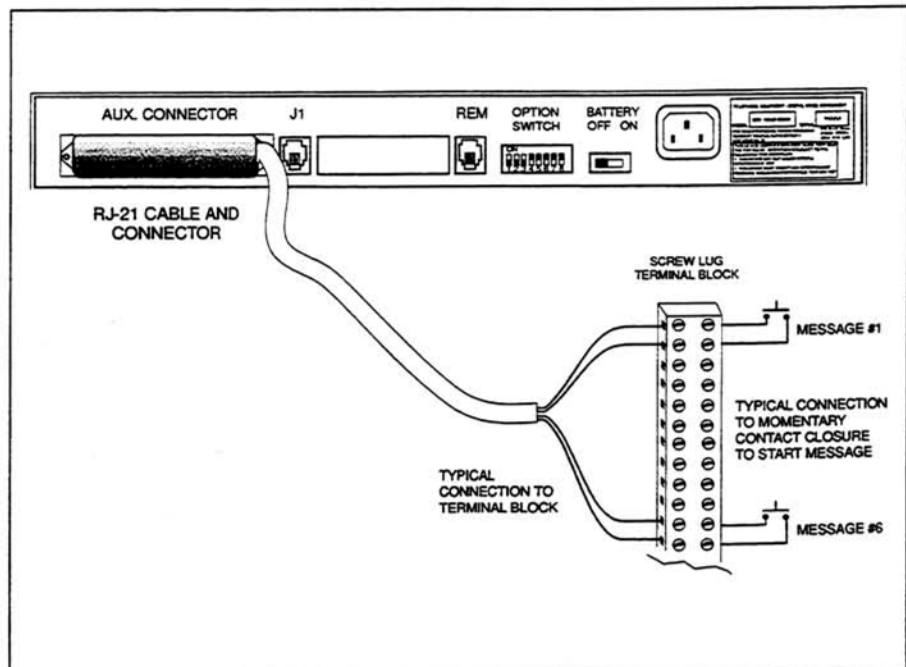

Figure 5 Connection of RJ-21 Cable to MDMU.

# 5

Set the MDMU options on the DIP switch. Refer to the table below.

*NOTE: Switches 1, 2, and 3 set the number of messages in a single queue sequence. The timing between those messages is set by switches 4, 5, and 6. Switch 7 sets the total possible number of messages for the unit. Switch 8 is always in the ON position.*

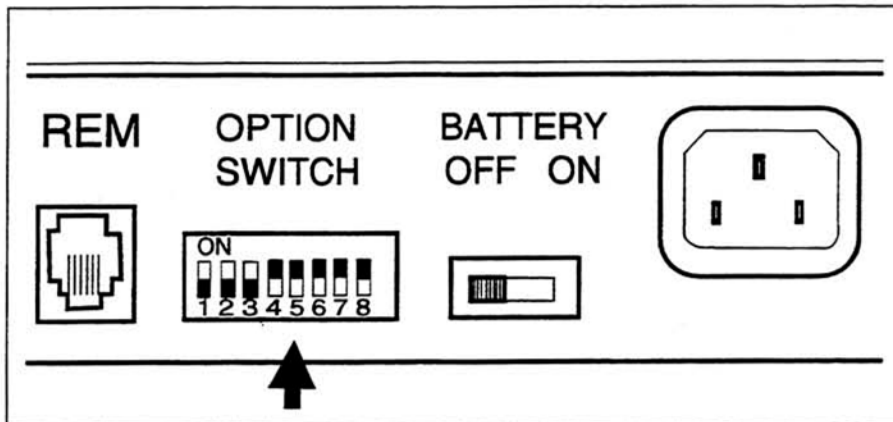

Figure 6 Set MDMU Options on DIP Switch

Table 1. DIP Switch Setting Definitions.

MAX. No. of MESSAGES IN SEQUENCE:	SET SWITCH # 1 TO	SET SWITCH # 2 TO	SET SWITCH # 3 TO	SET SWITCH # 4 TO	SET SWITCH # 5 TO	SET SWITCH # 6 TO	SET SWITCH # 7 TO
1	ON	ON	ON	—	—	—	—
2	OFF	ON	ON	—	—	—	—
3	ON	OFF	ON	—	—	—	—
4	OFF	OFF	ON	—	—	—	—
5	ON	ON	OFF	—	—	—	—
6	OFF	ON	OFF	—	—	—	—
7	ON	OFF	OFF	—	—	—	—
8	OFF	OFF	OFF	—	—	—	—
<b>DEFAULT DELAY BETWEEN MESSAGES:</b>							
0:05	—	—	—	ON	ON	ON	—
0:10	—	—	—	OFF	ON	ON	—
0:30	—	—	—	ON	OFF	ON	—
1:00	—	—	—	OFF	OFF	ON	—
5:00	—	—	—	ON	ON	OFF	—
15:00	—	—	—	OFF	ON	OFF	—
30:00	—	—	—	OFF	OFF	OFF	—
<b>NUMBER OF MESSAGES AVAILABLE:</b>							
1 TO 9	—	—	—	—	—	—	ON
01 TO 99	—	—	—	—	—	—	OFF

**1**

Plug the power cord into the A.C. input connector on the MDMU, then into the wall outlet.

The MDMU will display three messages in sequence:

MDMU 2.00

Software version of unit.

3:16

Total time available in memory for recording.

IDLE

Indicates the status MDMU: Idle = no activity; PLY = A message is being played out through connector J1; Delay = the time delay between successive messages is active.

**2**

Push the Battery slide switch to the ON position.

The MDMU is now ready to record and play messages.

*NOTE: The internal battery maintains the recorded messages two hours in the event of a power failure or brownout. Allow 48 hours to fully charge.*

*If power is to be removed from the MDMU for an extended period of time, turn the battery switch to the Off position to avoid permanent damage to the battery.*

*NOTE: The suggested reliable lifetime of the rechargeable battery used in the equipment is 36 months. To ensure the system has reliable battery backup, it is recommended the battery be replaced every 30 months.*

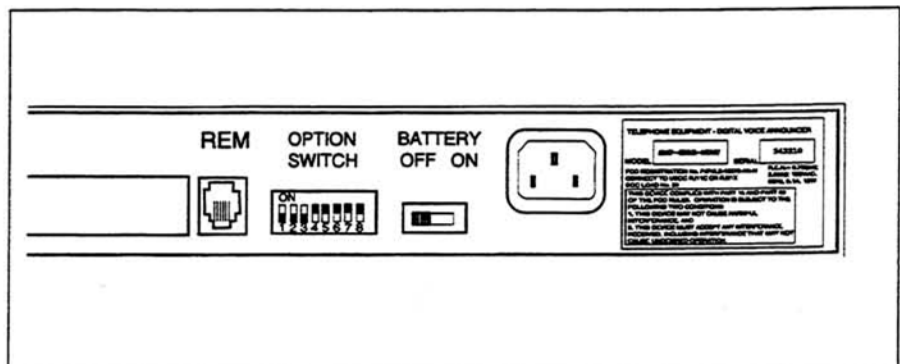

Figure 7 Battery Switch

# Front Panel Operation

The MDMU can record messages input from the front panel through the Hand Set, Tape, and Mic connectors. The unit can also record and store messages input remotely through telephone access to the REM port using a DTMF (touch tone) telephone.

## Controls and Indicators

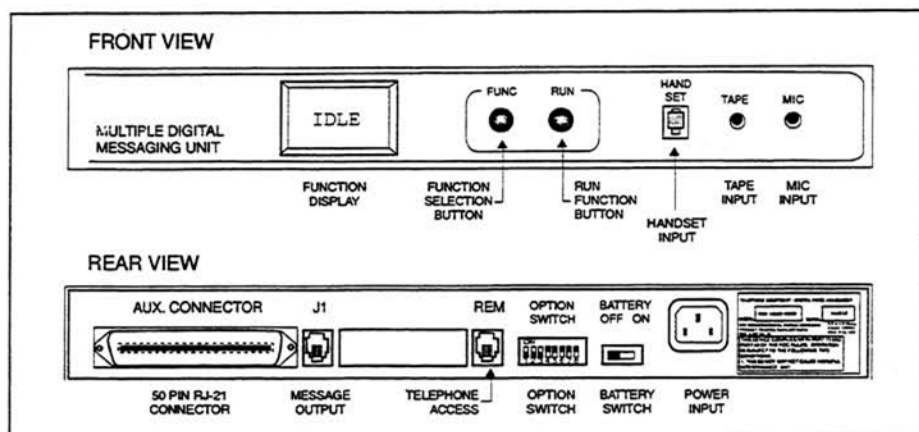

Figure 8 Controls and Indicators.

## Recording Messages

The highest priority message should be recorded on the lowest message number (1) to ensure fastest replay (i.e., Fire in Building...).

- 1** Plug the telephone handset, microphone, or tape player into the appropriate connector on the front panel.
- 2** Press the (black) FUNC button until the RECORD message is displayed.

**RECORD**

- 3** Press the (red) RUN button to display the message number #1.

*NOTE: Depending on number of messages optioned during installation (switch 7), the available message numbers will read 1 through 9, or 01 through 99.*

*NOTE: If the message number selected has been pre-recorded, a message will display "SURE ?" Press "RUN" again to append to the existing message.*

*During recording, the display will show the amount of memory remaining for the unit in minutes and seconds.*

*NOTE: While recording a message, pressing RUN will pause the recording. Press RUN again to continue.*

**4** To record on another message number, press the FUNC key until the desired message number appears.

**5** Press the RUN button and begin speaking into the handset, microphone, or press play on the tape player.

SURE ?

mm : ss

**6** When recording is complete, press the FUNC key.

The display shows the amount of time used for the message:

TIME

0.30

DONE

IDLE

**7** Repeat steps 2 though 6 to record other messages.

---

# Listening to Recorded Messages

---

*NOTE: Use the front panel handset to listen to messages.*

- 1** Press the FUNC button until the display indicates monitor.

MONITOR

- 2** Press the RUN button to select the message number.

MSG - 01

- 3** Press the FUNC key until the desired message number appears.

MSG - 11

- 4** Press RUN to listen to the message.

*As the message plays into the handset, the display counts down the message time.*

mm : ss

Length of message.

DONE

Done playing message.

---

## Playing Messages

---

Once messages have been recorded, they may be played over the paging system as described below. Messages can also be queued by a contact closure of one of the switch cable pair of the RJ-21 cable (See figure 5).

- 1** Press the FUNC button until PLAY is displayed.

PLAY

- 2** Press the RUN button.

MSG - 01

The first message is displayed.

- 3** Press the FUNC button to select a message other than MSG-01 to play in.

MSG - 09

- 4** Press RUN to play the message.

PLY - S09

Ply = Play, message #9 out of sequence.

DEL - S09

Configured delay between the messages (see table 1).

*NOTE: If a contact closure comes in on the RJ-21 cable, the message sequence will stop. The contact closure message will play until the closure is removed. The sequence message will resume where it left off.*

---

## Playing Messages in Sequence

---

A group or sequence of messages can be played to the output channel. The maximum number of messages in a sequence can be up to 8 (determined by the DIP switch settings on the back panel). To add messages to the sequence simply repeat the PLAY command, selecting the message to be added each time.

- 1** Press the FUNC button until PLAY is displayed.

PLAY

- 2** Press the RUN button.

MSG - 01

The first message is displayed.

- 3** Press the FUNC button to select a message other than MSG-01 to play in:

MSG - 09

- 4** Press RUN to play (and group) the message.

PLY - S09

Ply = Play, S = sequence message #9.

- 5** Repeat steps 1 through 4 to add up to 8 messages if you are configured for 8 (see page 9).

*NOTE: If a contact closure comes in on the RJ-21 cable, the message sequence will stop. The contact closure message will play until the closure is removed. The sequence message will resume where it left off.*

---

## Adding a Time Delay Between Message Plays

---

A time delay can be inserted before successive message plays. The amount of time depends on the maximum time delay set on the option DIP switch.

- 1** Press the FUNC button until DELAY appears.

DELAY

- 2** Press the RUN button to display the message numbers.

MSG - 01

- 3** Press the FUNC button to select the message number to add the delay.

MSG - 04

- 4** Press the RUN button to display the delay times.

DLY - 0 : 05

- 5** Press the FUNC button to scroll the available delay times.

DLY - 0 : 30

30 second delay

- 6** Press the RUN button to accept the selected delay time.

DONE

- 7** Repeat steps 1 through 6 to add delays to other message numbers.

*NOTE: A delay may only be selected for a message which has previously been recorded.*

---

## Clearing a Message Sequence

---

The message sequence can be cleared leaving the individual messages to be played separately.

- 1** Press the FUNC button until PLAY is displayed

PLAY

- 2** Press the RUN button.

MSG - 01

- 3** Press the FUNC button until the following message is displayed.

MSG - 00

This is the message abort number.

- 4** Press RUN to clear the message sequence.

CLEARED

DONE

IDLE

---

## Checking Message Times

---

The TIME function displays the time used for each message recorded. It also displays the remaining time available in system memory to record other messages.

- 1** Press the FUNC button until TIME appears.

TIME

- 2** Press the RUN button (once) to view message numbers and recording time.

MSG - 01

Message number.

mm : ss

Time used to record message in minutes and seconds.

- 3** Once all messages and times are displayed, the display indicates:

LEFT

Amount of time left on the system to record other messages.

2 : 09

Available MDMU memory time in minutes and seconds.

DONE

---

## Reset Delay Times to Default

---

The INIT (initialize) function resets the operating parameters and delay time to the default setting of five seconds without effecting the recorded messages.

- 1** Press the FUNC button until INIT appears.

INIT

- 2** Press the RUN button.

SURE ?

Verification of command.

- 3** Press the RUN button again to initialize.

WAIT

DONE

---

## Audio and Memory Tests

---

Two diagnostic tests are built into the MDMU internal software. The audio test plays a 1000 Hz tone to the installed J1 output line. The memory test clears all recorded messages and internally writes and reads a number of test patterns to verify proper operation.

### Audio Test

- 1** Press the FUNC button until TEST appears.

TEST

- 2** Press the RUN button to display the test options.

AUD TEST

- 3** Press the RUN button again to begin the test.

**4**

Press the FUNC button to end the continuous audio test.

WAIT

IDLE

### Memory Test

**1**

Press the FUNC button until TEST appears.

TEST

**2**

Press the RUN button to display the test options.

AUD TEST

**3**

Press the FUNC button to select the memory test.

MEM TEST

**4**

Press the RUN button to initialize the test.

SURE ?

Verification of memory test command.

**5**

Press the RUN button again to begin the test.

ADD TEST

0

This number indicates the number of times the memory test has executed.

**6**

Press the FUNC button to end the test.

DONE

*CAUTION! The memory test will erase all recorded and stored messages.*

*To cancel the memory test command, press the FUNC button.*

# Telephone Access Operation

---

The MDMU may be accessed remotely using a DTMF (Touch Tone) telephone. Telephone access can be made directly through a telephone switching system with one of its analog stations connected to the MDMU REM port.

## Recording Messages

---

- 1** Dial the telephone extension of the MDMU.
- 2** Press \* 7 (R for record) and the message number.  
(for example, \* 76 - record message number 6)
- 3** When you hear the beep, begin recording the message.
- 4** Optionally, to send this message to a particular paging zone, dial the zone number now, then continue recording this message.
- 5** Press the # key to end recording and save message.
- 6** Press the # key again to disconnect from the MDMU.

## Listening to Recorded Messages

---

- 1** Dial the telephone extension of the MDMU.
  - 2** Press \* 6 (M for monitor) and the message number.  
(for example, \* 609 - monitor message number 9)
- Press the # key to end monitoring message.
- Press the # key again to disconnect from the MDMU.

---

## Playing Messages

---

- 1** Dial the telephone extension of the MDMU.
- 2** Dial the message number to play over the public address system (for example, **14**, for message number 14).  
  
The message is played and added to the sequence of messages playing.  
  
Press the **#** key to disconnect from the MDMU.

---

## Clearing a Message Sequence

---

- 1** Dial the telephone extension of the MDMU.
- 2** Press **0** (or **00** if set for 99 messages).  
  
This action removes all messages from the sequence, stops any contact closure message starts, and places the MDMU in the IDLE state.
- 3** Press the **#** key to disconnect from the MDMU.

# Specifications

Table 2 lists the specifications for the Multiple Digital Messaging Unit. Figure 9 on the next page gives the Aux. Connector pin-out definitions.

Table 2 Multiple Digital Messaging Unit Specifications.

Power Supply	<ul style="list-style-type: none"> <li>■ 115 VAC, 60 Hz, or 220 VAC, 50 Hz (specified on MDMU rear panel).</li> </ul>
Dimensions and Weight	<ul style="list-style-type: none"> <li>■ Height: 1.75 inches (4.4 cm).</li> <li>■ Width: 16.25 inches (41cm) without brackets, 19 inches (48.3 cm) with brackets attached.</li> <li>■ Depth: 9.25 inches (23.5 cm).</li> <li>■ Weight: 13 pounds (6 kg).</li> </ul>
Fuse Ratings	<ul style="list-style-type: none"> <li>■ AC Power: MDL 0.25 amp Slow Blo.</li> <li>■ Battery: MDL 2.0 amp Slow Blo.</li> </ul>
Temperature Range:	<ul style="list-style-type: none"> <li>■ 0 to +40 deg. C. (32 to 104 deg. F.) operational.</li> <li>■ -40 to +66 deg. C. (-40 to +150 deg. F.) storage and shipment.</li> </ul>
Humidity Range:	<ul style="list-style-type: none"> <li>■ 5% to 95% (non-condensing) storage/shipment and operation.</li> </ul>
Altitude:	<ul style="list-style-type: none"> <li>■ Sea level to 10,000 ft. operational (1048 to 648 millibars) 40,000 ft. max. shipment.</li> </ul>
Environmental	<ul style="list-style-type: none"> <li>■ Locate in an area free of excess moisture, corrosive gases, dust, and chemicals.</li> </ul>
Battery Backup	<ul style="list-style-type: none"> <li>■ Allows up to two hours of operation during a power failure. Total charge time 48 hours.</li> </ul>
Frequency Response	<ul style="list-style-type: none"> <li>■ - 200 Hz to 3.4 kHz ( ±3 dB).</li> </ul>
Output Level	<ul style="list-style-type: none"> <li>■ Adjustable to a maximum of -9 dBm.</li> </ul>
Input Impedance	<ul style="list-style-type: none"> <li>■ Handset: 220 ohms; Microphone: 600 ohms; Tape: 10K ohms.</li> </ul>
Voice Encoding	<ul style="list-style-type: none"> <li>■ 8 kHz sampling rate, 8 bits/sample (PCM).</li> </ul>
Interconnect Cable	<ul style="list-style-type: none"> <li>■ 50 pin, RJ-21 connector providing contact closure message starts.</li> </ul>

PIN	WIRE COLORS		DEFINITION
1	BLUE	WHITE	J1 RING
2	ORANGE	WHITE	CP 1 (C)
3	GREEN	WHITE	CP 1 (NC)
4	BROWN	WHITE	CP 1 (NO)
5	SLATE	WHITE	
6	BLUE	RED	
7	ORANGE	RED	
8	GREEN	RED	
9	BROWN	RED	
10	SLATE	RED	
11	BLUE	BLACK	
12	ORANGE	BLACK	
13	GREEN	BLACK	
14	BROWN	BLACK	
15	SLATE	BLACK	
16	BLUE	YELLOW	
17	ORANGE	YELLOW	
18	GREEN	YELLOW	
19	BROWN	YELLOW	
20	SLATE	YELLOW	
21	BLUE	VIOLET	
22	ORANGE	VIOLET	
23	GREEN	VIOLET	
24	BROWN	VIOLET	
25	SLATE	VIOLET	RING REMOTE
26	WHITE	BLUE	J1 TIP
27	WHITE	ORANGE	START 1 (-)
28	WHITE	GREEN	START 1 (+)
29	WHITE	BROWN	
30	WHITE	SLATE	
31	RED	BLUE	START 2 (-)
32	RED	ORANGE	START 2 (+)
33	RED	GREEN	
34	RED	BROWN	
35	RED	SLATE	START 3 (-)
36	BLACK	BLUE	START 3 (+)
37	BLACK	ORANGE	
38	BLACK	GREEN	
39	BLACK	BROWN	START 4 (-)
40	BLACK	SLATE	START 4 (+)
41	YELLOW	BLUE	ALARM (NC)
42	YELLOW	ORANGE	
43	YELLOW	GREEN	START 5 (-)
44	YELLOW	BROWN	START 5 (+)
45	YELLOW	SLATE	ALARM (NO)
46	VIOLET	BLUE	
47	VIOLET	ORANGE	START 6 (-)
48	VIOLET	GREEN	START 6 (+)
49	VIOLET	BROWN	ALARM (C)
50	VIOLET	SLATE	TIP REMOTE

Table 3

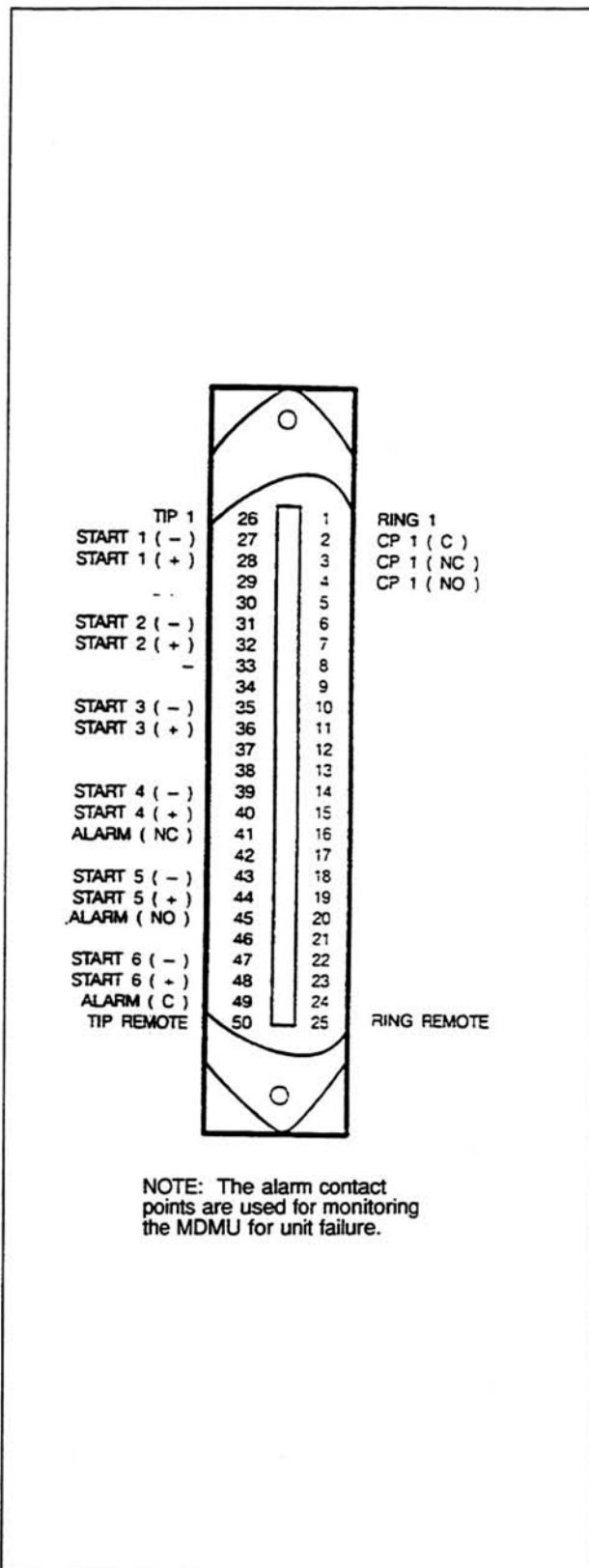

Figure 9 50 Pin Connector and Wiring Code.